

Data Sheet



Article number: 170304500800100111

Description: Oil seal VIA FPM 4580/10 FPM
for gearbox W 86 input (i=45-100)

Measures

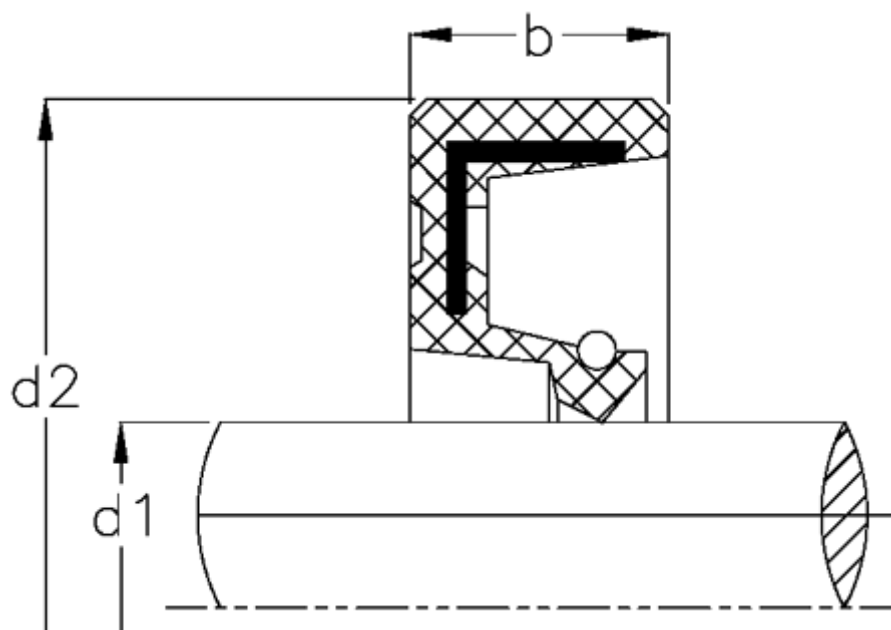

b	= 10
d1	= 45
d2	= 85
Material	= FPM